

Date

March 13, 2020

Released

- Specification -

C-band LNA

Model No. NJS8451 series

Model No.	RF Frequency
NJS8451	4.5 to 4.8 GHz
NJS8452	3.4 to 4.2 GHz

RF Input Interface: Waveguide, CPR-229G

RF Output Interface: N-type, Female Connector

DC Power Input: RF Output Interface Connector

DC Power Voltage Range: +12 to +28 V

Copyright ©

New Japan Radio Co., Ltd.

Microwave Division

-Notice of Proprietary Information-

This document and contents are proprietary to New Japan Radio Co., Ltd.
This publication and contents may not be reproduced or distributed for any other purpose
without the written permission of New Japan Radio Co., Ltd.
Specifications listed in this document are subject to change at any time, without notice.

New Japan Radio Co., Ltd.
Microwave Division

Title:

Datasheet of NJS8451 series

Reference No.:

DS-S8451

Rev.:

10E

Sheet:

1 / 14



Caution

1. While New Japan Radio., Ltd.(NJR) continually strives to improve the quality and reliability of any products, failures would occur in microwave products over time. For this reason, it is important that customers fulfill their responsibilities to ensure designed-in safety – including failsafe functions, redundancy, and measures to prevent malfunctions and the spread of fire – in order to avoid injuries, accidents, or social repercussions resulting from the failure of any product related to satellite communications on this document (hereinafter, “the product”). Customers must pay careful attention to ensuring the safety of their equipment.
2. The product is designed and tested to function in accordance with its specifications. Do not use under conditions that deviate from the product specifications included in the specifications. NJR assumes no responsibility and shall not be liable for any injuries, accidents, or social repercussions resulting from the product being in a poor or damaged state because it was used under conditions that depart from the specifications.
3. The product is covered by a warranty for one year following delivery unless otherwise stipulated in the contract or delivery conditions. In the event of a failure for which NJR are responsible occurring during the warranty period, NJR undertake to repair or replace the product free of charge. Note, however, that the warranty does not cover failures such as those listed here (see bullets below), even if they occur within the warranty period. In addition, in the case of a product being repaired or replaced by us, the starting date for the warranty period is still the original delivery date of the product.
 - Failure due to the product being used in conditions other than those stipulated in the data sheet, specification sheet, etc.
 - Failure due to modifications or repairs carried out by some entity other than our company
 - Failure determined to be the result of unsuitable maintenance or replacement of a consumable item that requires due maintenance
 - Failure due to circumstances that were unforeseeable given the scientific/technological standards at the time of shipment
 - Other failures due to external factors such as fire, earthquake, flood and power supply anomalies for which NJR are not responsible

In addition, the product warranty is limited to the provision of repair services or replacement at no cost. It does not cover secondary damage (to equipment, business opportunities, profits, etc.) or any other damage that may have resulted from failure of the product.
4. The product must be handled appropriately to ensure its continued reliability. Since it can be damaged by the intrusion of water, dust, oil, chemicals, etc., it must be given appropriate protection. Even in the case of a product with an airtight construction, avoid using it in an environment that exceeds the stated levels of waterproofing/dustproofing. Also, be sure to use connectors and waveguides properly.

If replacement parts such as fans are included, proper maintenance is necessary. To maintain product performance and functionality, it is necessary to conduct inspections and maintenance at appropriate intervals and exchange replacement parts when necessary. Improper inspections or maintenance may result in failure.

In addition, the warranty does not cover the use of the product in areas where salt damage can be expected or where there is a substantial presence of corrosive gases such as Cl₂, H₂S, SO₂, and NO₂. If the product is to be used in such areas, at the time of installation you must take appropriate steps to protect the product.
5. If the product is to be used with equipment/systems that must meet special quality and reliability standards (aerospace equipment, medical equipment, power generation control equipment, automotive/railway transportation equipment, safety equipment, disaster prevention and security equipment, etc.), please consult with our sales staff in advance.
6. This product contains gallium arsenide (GaAs), classified as a harmful substance. To avoid danger, do not incinerate, crush, or chemically treat the product in such a way that gases or dust are released. When disposing of the product, comply with all applicable laws and regulations and do not treat it as general industrial waste or household waste.
7. When exporting a product or technology, observe export laws and regulations such as those governing foreign exchange and foreign trade, and obtain any necessary licenses for export, service transactions, etc. NJR request that you do not use our products or the technical data published on this document for developing weapons of mass destruction or for any other military purposes or applications.
8. The product specifications in this document are subject to change without notice. If you are considering using a product, delivery specifications must first be settled.

*Above specifications are subject to change without notice.

Scope

This LNA is intended for the satellite communication data downlink application in C-band. It is combined a 3-stage HEMT amplifier.

The LNA receives an RF signal (C-band: 3.4 to 4.2 GHz, or 4.5 to 4.8 GHz) as input, amplifies and outputs the RF signal. It is operated by +24 V DC power (range: +12 to +28 V) input.

The LNA comes in a single, weatherized housing rated for outdoor use, and has a CPR-229G waveguide flange as RF input and an N-type female connector as RF output.

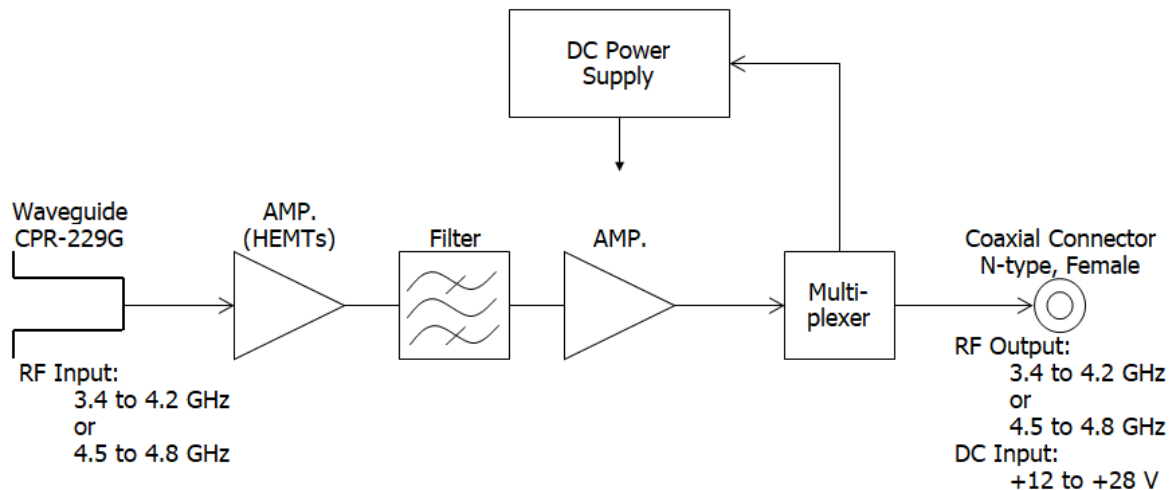
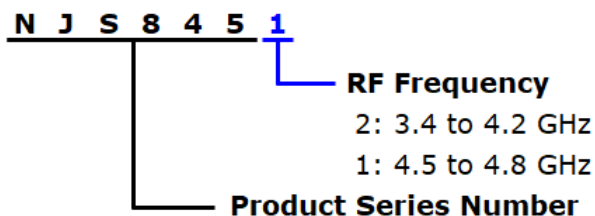

Fig.1 Functional Block Diagram

Series Model Number

- Numbering System



- Line-up

Model No.	RF Frequency	IF Connector
NJS8452	3.400 to 4.200 GHz (Palapa C-band)	N-type
NJS8451	4.500 to 4.800 GHz (Insat C-band)	N-type

* Above specifications are subject to change without notice.

1. Electrical Specifications

#	Items	Specifications
1.1.	Absolute Maximum Rating [RF Input Power] [Supply Voltage]	-10 dBm (@ CW), +10 dBm (@ Pulse) +30 V DC
1.2.	Input RF Frequency Range < Model No. NJS8451 > < Model No. NJS8452 >	 4.5 to 4.8 GHz 3.4 to 4.2 GHz
1.3.	Input RF Level	-135 to -65 dBm
1.4.	Noise Temperature @ +25 °C	15 K typ., 30 K max.
1.5.	Conversion Gain @ +25 °C < Model No. NJS8451 > < Model No. NJS8452 >	 55 dB min., 62 dB max. 48 dB min., 55 dB max.
1.6.	Conversion Gain Ripple @ +25 °C	2 dBp-p max. at any 50 MHz segments.
1.7.	Conversion Gain Flatness over Frequency @ +25 °C < Model No. NJS8451 > < Model No. NJS8452 >	 3 dBp-p max. over 300 MHz BW 5 dBp-p max. over 800 MHz BW
1.8.	Conversion Gain Variation over Temperature	5 dB max.
1.9.	Output Power @ 1dB G.C.P. (P1dB)	+7 dBm min.
1.10.	Output Intercept Point	+19 dBm min.
1.11.	Output V.S.W.R.	2 : 1 typ., 3 : 1 max.
1.12.	Power Requirement [Input Port] [Input Voltage] [Current Drain]	RF Output Interface Connector (Combine DC Power with Output RF Signal) +12 to +28 VDC 125 mA typ., 160 mA max.

* Above specifications are subject to change without notice.

2. Mechanical Specifications

#	Items	Specifications
2.1.	Input Waveguide Flange	Waveguide, CPR-229G (with Groove)
2.2.	RF Interface Connector	Coaxial Connector , N-type Female - 50 ohms
2.3.	Dimension & Housing without Interface Connector	80.8 (L) x 99.6 (W) x 76 (H) mm [3.18" (L) x 3.92" (W) x 2.99" (H)]
2.4.	Weight	800 g [1.76 lbs]

3. Environmental Specifications

#	Items	Specifications
3.1.	Temperature Range (Ambient) [Operating] [Storage]	-40 to +60 °C -40 to +80 °C
3.2.	Humidity	0 to 100 % RH
3.3.	Altitude	15,000 feet (4,572 m)
3.4.	Vibration (Survival)	5 G [49.03 m/s ²] (3 axis, 50 Hz)
3.5.	Shock (Survival)	15 G [147.1 m/s ²] (3 axis)
3.6.	Waterproof / Dustproof (IP Code Rating)	IP 67
3.7.	Regulations	EU Directive (CE Marking) EMC - 2014/30/EU RoHS - 2011/65/EU + (EU)2015/863 Safety: EN60950-1
3.8.	MTBF (by Method of Parts Count Reliability Prediction)	150,000 hours and more at +60 °C as Design Condition

* Above specifications are subject to change without notice.

4. Outline Drawing

(e.g. NJS8452)

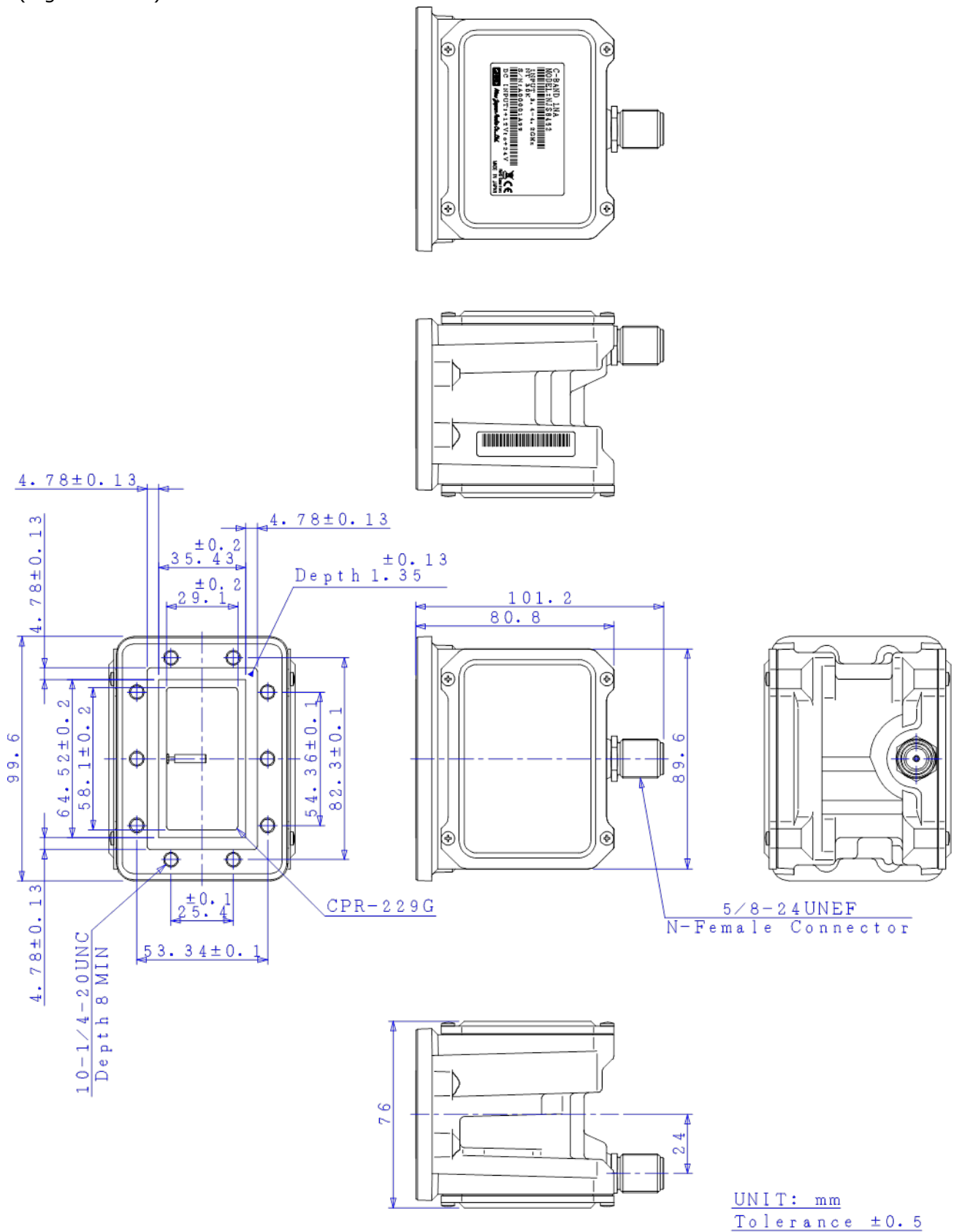

UNIT: mm
Tolerance ± 0.5

*Above specifications are subject to change without notice.

5. Label

5.1. Label Outline (e.g. NJS8452)

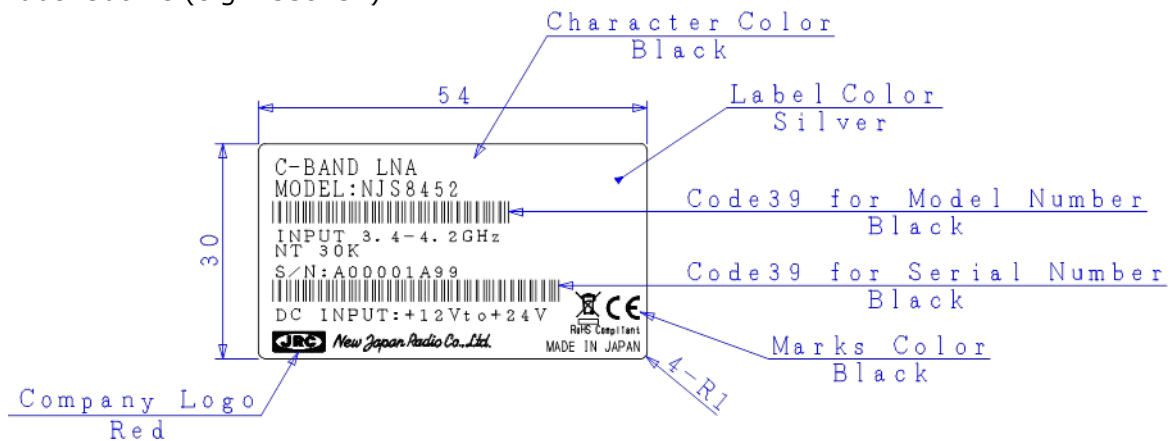

5.2. Definitions

Serial Number (OSSSSRYM) - ALPHANUMERIC (9 characters)

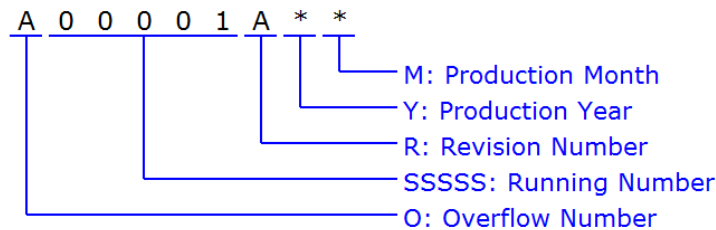

O: Overflow Number - ALPHABET (1 character)

"A" to "Z", e.g.: A99999 ⇒ B00001

SSSS: Running Number - NUMBER (5 digits)

"00001" to "99999"

R: Revision Number - ALPHABET (1 character)

"A" to "Z"

Y: Production Year - NUMBER (1 digit)

Calendar Number, e.g.: 2009:9, 2010:0, 2011:1, 2012:2 ···

M: Production Month - ALPHANUMERIC (1 character)

"1" to "9", "X" as October, "Y" as November, "Z" as December

* Above specifications are subject to change without notice.

6. Package

6.1. Individual Package / Shipping Package

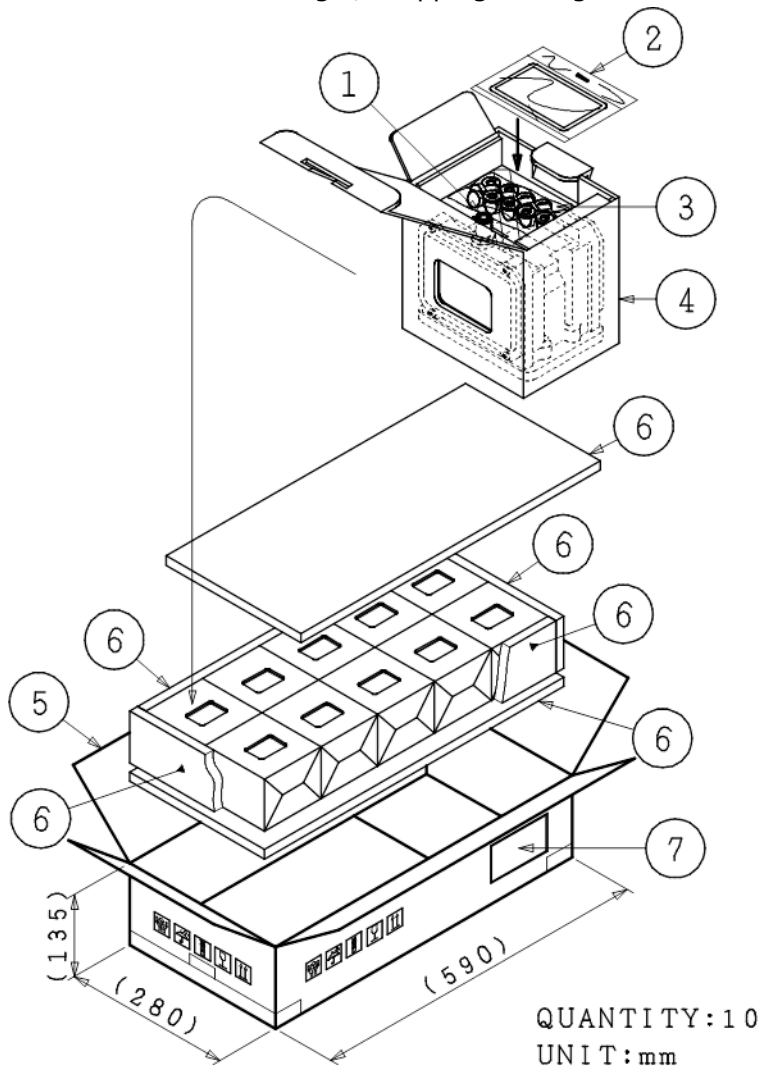

- ①: C-PLL LNB
 ②: Accessory
 · O-RING (FULL)

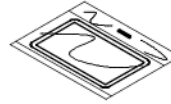

- ③: Accessory
 · Hexagon head bolts
 1/4-20UNC×5/8(SUS) 10 pieces
 · Spring lock washers
 1/4-20UNC(SUS) 10 pieces
 for Waveguide Flange Holes



- ④: Single Wall Corrugated Fiberboard
 ⑤: Double Wall Corrugated Fiberboard
 ⑥: Polystyrene Foam
 For Package Cushioning
 ⑦: Package Label

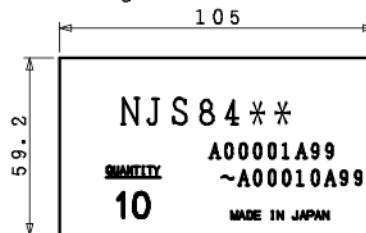

Pictorial Marking for Handling of Goods

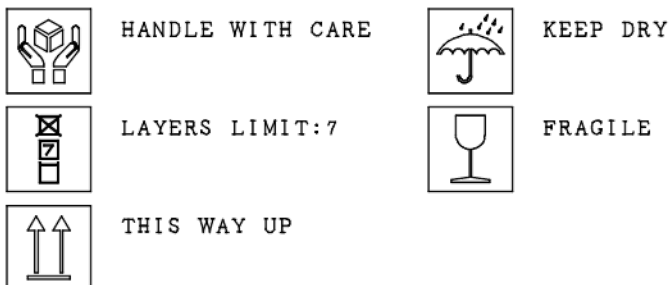

* Above specifications are subject to change without notice.

6.2. Enclosed Accessories

- O-ring Gasket, Qty (1), Full-type, for Waveguide Flange
- Bolts, Qty (10), #1/4-20UNC x 5/8", Hexagon Head, SUS
- Spring Washers, Qty (10), SUS

* Above specifications are subject to change without notice.

7. Handling Precautions

7.1. DANGER



This statement indicates an imminently hazardous situation which, if not avoided, will result in death or serious injury.

Items	Description
Input Voltage	Only input a DC voltage within the range indicated in specifications. <u>Do</u> operate with the input voltage range between +12 and +28 V DC power. When applying higher voltage than specifications (+30 V as absolute maximum rating), it will not only cause this unit failure, but it may also result in <u>electric shock</u> and <u>fire</u> .
Disassembling	<u>Do not</u> disassemble the unit. Disassembling will not only cause this unit failure, but it may also result in <u>electric shock</u> .

7.2. CAUTION



This statement indicates a potentially hazardous situation which, if not avoided, could result in minor or moderate injury. The statement may also be used to indicate other unsafe practices or risks of property damage.

Items	Description
Disposal	This unit contains gallium arsenide (GaAs), classified as a harmful substance. To avoid danger, <u>do not</u> incinerate, crush, or chemically treat the unit in such a way that gases or dust are released. When disposing the unit, comply with all applicable laws and regulations and do not treat it as general industrial waste or household waste.

7.3. NOTE



This statement is used to notify of installation, operation, or maintenance information that is important, but not hazard-related.

Items	Description
Torque Management	<u>Do not</u> tighten with excessive torque when attaching screws/bolts and connectors. The following value as tighten torque is recommended. <ul style="list-style-type: none"> ■ Screws/Bolts - #1/4-20UNC: 5.11 to 5.24 N·m ■ RF Connector (N-type): 0.68 to 1.13 N·m

*Above specifications are subject to change without notice.

Items	Description
Weatherproof	<p>The unit mounted in outdoor should be conducted with adequately weatherproof procedure.</p> <p>Do seal all of cable connection points from the connector to the cable sheath by usage of self-amalgamating tape.</p> <p>Ensure the waveguide connection is properly assembled with the enclosed o-ring gasket as accessories. The o-ring gasket is full-type and it is assumed to connect the unit to a grooved waveguide flange.</p>
Input Voltage	<p><u>Do</u> operate with the input voltage range between +12 and +28 V DC power. Avoid applying more than the maximum voltage in this range (including ripple voltage) under any conditions.</p>
Input RF Signal Power	<p><u>Do not</u> supply the input RF signal over the absolute maximum rating indicated in specifications (-10 dBm @ CW / +10 dBm @ Pulse).</p>
High Temperature Operation	<p>It may cause damage and/or degradation of reliability / lifetime to operate the unit in a condition where the ambient temperature exceeds the maximum value, <u>+60 °C</u>, at operating temperature described in the specifications.</p>
Vibration / Shock	<p>When vibration and/or shock impact exceeding the conditions described in the specifications is applied, internal parts may be damaged.</p>
Warranty	<p>The unit is covered by a warranty for one(1) year following delivery unless otherwise stipulated in the contract or delivery conditions.</p> <p>Repairs may be possible under payment of charge even for the unit whose warranty period has expired.</p> <p>Opening, removing, disassembling and modifying any parts and components (including the product label, sealing tape and screws) without fan equipment will immediately void the warranty.</p> <p>In any case, the unit of invalid warranty cannot be repaired.</p>

* Above specifications are subject to change without notice.

8. Instructions Manual

8.1. Descriptions

This section describes the information of connectors and etc.

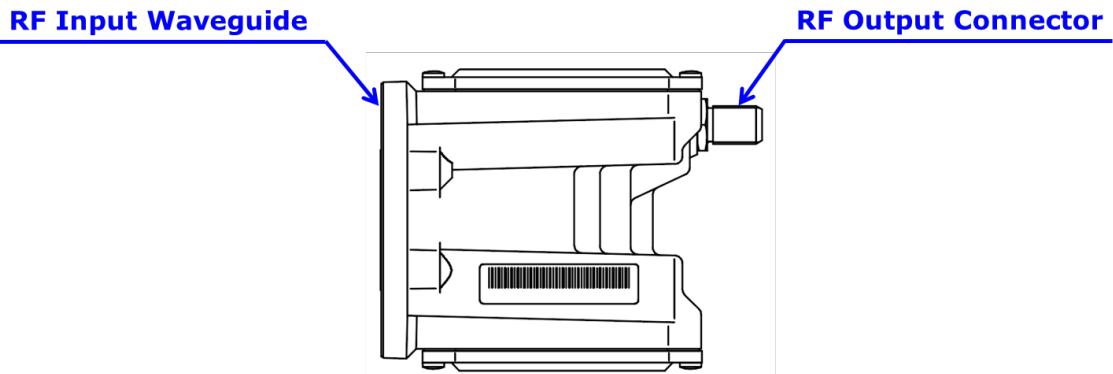

Items	Description	Purpose
RF Input Waveguide	Waveguide: WR-229 Flange: CPR-229G (with Groove)	The LNA receives an RF signal of C-band (3.4 to 4.2 GHz, or 4.5 to 4.8 GHz) via this waveguide.
RF Output Connector	N-type Female Coaxial Connector, 50 Ohms	The LNA outputs an RF signal of C-band (3.4 to 4.2 GHz, or 4.5 to 4.8 GHz) and requires to supply +12 to +28 V DC power via this connector.

8.2. Connection and Installation

This section describes basic installation for the LNA.

8.2.1. Mounting Configuration

The Unit can be mounted with OMT or the waveguide filter of the satellite antenna.

When mounting with the OMT or the waveguide filter, the following steps should be complied:

Step 1: Verify that the groove on the waveguide flange for a gasket is clean.

The enclosed gasket as accessories is full-type and it is assumed to connect the LNB to a grooved waveguide flange. Insert the gasket the groove as shown in the figure on the right

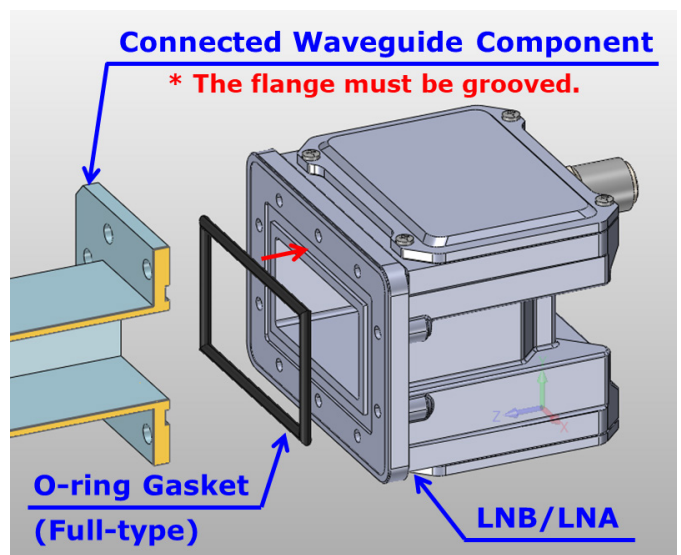

* Above specifications are subject to change without notice.

Step 2: Secure the OMT or the filter to the LNA by tightening the enclosed hexagon head bolts (#1/4-20UNC L = 5/8") with 5.11 to 5.24 N·m torque as shown in the figure below, when the thickness of the flange of the OMT or filter is assumed to be 7 to 10 mm. The enclosed washers as accessory must be inserted to bolts before tightening bolts.

When the thickness is other than 7 - 10 mm, the appropriate length screws or bolts based should be prepared on the table on the right.

Flange Thickness of OMT/Filter	Screw Length
4 to 7 mm [0.15" to 0.275"]	1/2"
7 to 10 mm [0.275" to 0.4"]	5/8"
10 to 13 mm [0.375" to 0.525"]	3/4"

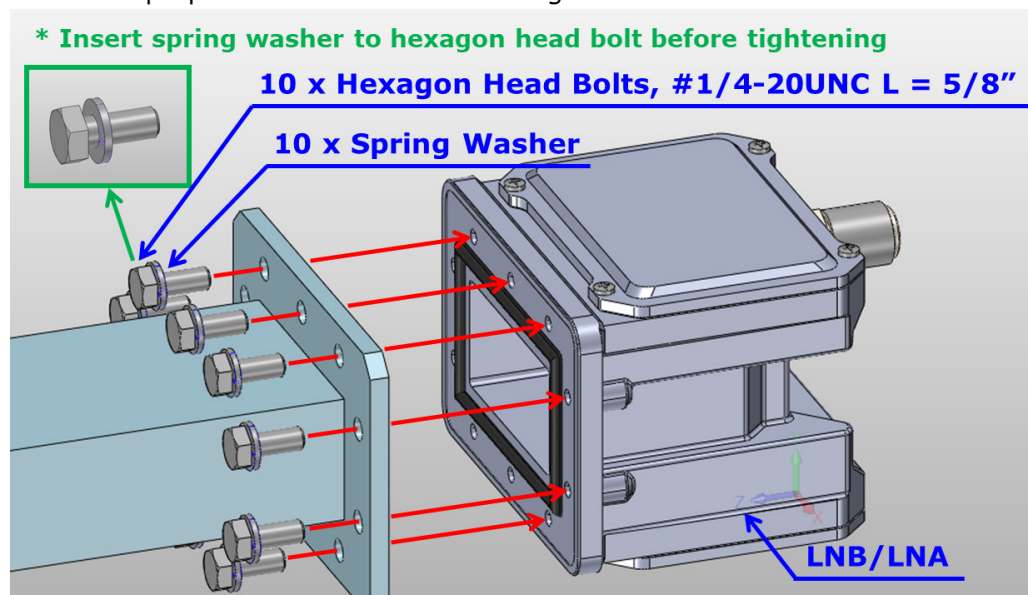

8.2.2. Connecting Coaxial Cable

The LNA is connected the modem with a coaxial cable, and requires to supply +12 to +24 V DC power from the modem. For external reference models, a 10 MHz reference signal shall be supplied.

The connection of coaxial cable should be complied with the following steps:

- Step 1: Connect the coaxial cable with the N-type male connectors to the coaxial connector equipped with the LNA which is shown in the figure on the right below under 0.68 to 1.13 N·m tighten torque.
- Step 2: Use self-amalgamating tape to seal connector and cable entry points from the connector to the cable sheath.

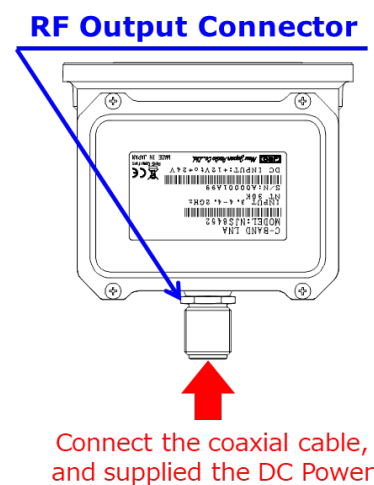

Do not power on the modem before finishing all of steps of Connecting Coaxial Cable.

* Above specifications are subject to change without notice.

8.2.3. Start-up

Start-up will be immediately performed with the following step:

Step: Power on the modem and supply the DC voltage (and 10 MHz reference) from modem.



DANGER

- ✓ Only input a DC voltage within the range indicated in specifications.
Do operate with the input voltage range between +12 and +28 V DC power.
When applying higher voltage than specifications (+30 V as absolute maximum rating), it will not only cause this unit failure, but it may also result in electric shock and fire.



NOTE

- ✓ Do not power on the modem before finishing all of steps of Connecting Coaxial Cable.
- ✓ The LNA must be adequately weatherproofed to place in outdoor.
 - Ensure that the waveguide joint is properly sealed with the enclosed o-ring gasket.
 - Do seal all of cable connection points from the connector to the cable sheath by usage of self-amalgamating tape.

* Above specifications are subject to change without notice.